

JCB

3/4" AIR IMPACT WRENCH INSTRUCTION & USER MANUAL

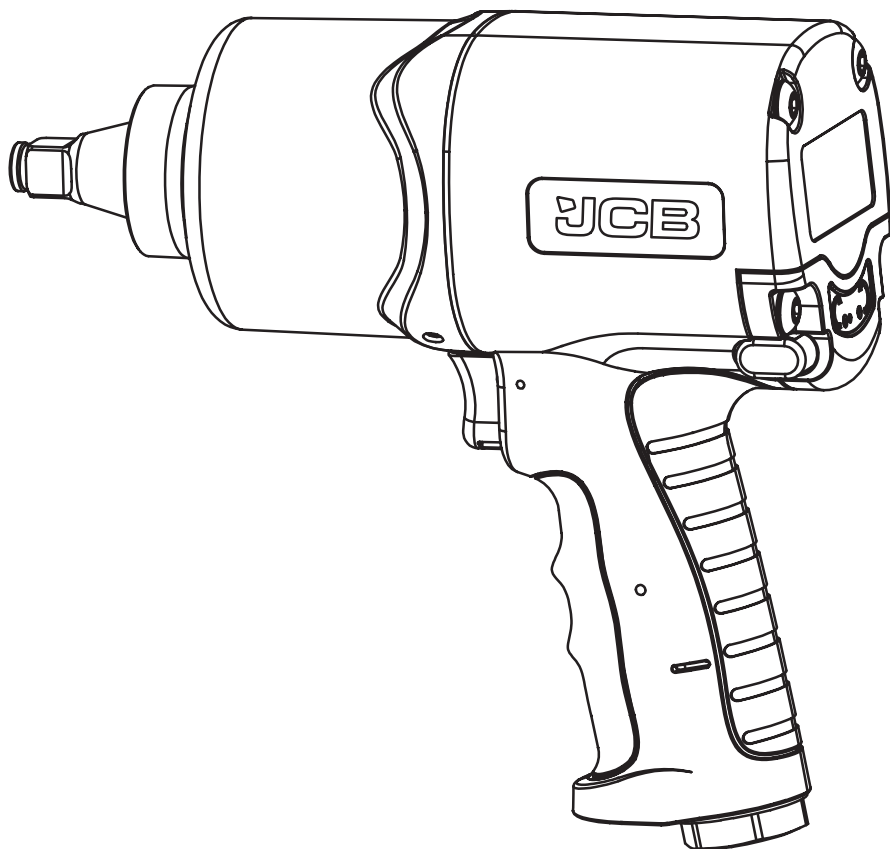

RP7460

Original Instructions

IM-RP7460-EN
Iss: 07/2023

EAC CE



EN

GENERAL WARNINGS & DISPOSAL



To reduce the risk of injury, the user must read the instruction manual.



This symbol is used throughout this manual to warn the user about potential risks. Please read & understand these sections before using the device.



Caution! Wear ear-muffs. The impact of noise can cause damage to hearing.



Caution! Wear protective safety gloves.



Caution! Wear safety goggles. Sparks generated during working or splinters, chips and dust emitted by the device can cause loss of sight. wood and other materials. Never use the device to work on any materials containing asbestos!



Caution! Wear a breathing mask. Dust which is injurious to health can be generated when working on wood and other materials. Never use the device to work on any materials containing asbestos!

The month and year of manufacture can be found within the product serial number e.g. MMYYPXXAXXXXXX. Where production month (MM) and production year (YY) are included.

Contents

INTRODUCTION	4
SAFETY PRECAUTIONS	4
AIR SUPPLY AND CONNECTION REQUIREMENTS	4
WARNING	4
IDEAL SYSTEM CONNECTION	5
MAINTENANCE	6
SPECIFICATIONS	6
PARTS OF THE IMPACT WRENCH	7
WARRANTY STATEMENT	8-9
DECLARATION OF CONFORMITY	10



INTRODUCTION

For your safety, please read this manual before using any lifting equipment ensuring you fully understand its operation and the safety procedures to be observed. Ensure this manual is retained for future reference and that new users of this product read and understand the content before they use the product.

SAFETY PRECAUTIONS

WARNING!

Failure to comply with these instructions can cause serious injury and damage to the vehicle. If you are in any way unsure, do not attempt to use this product and consult a qualified mechanic.

Air supply and connection requirements:

1. Read and understand instruction manuals fully before use. Use only as specified.
2. The maximum recommended air pressure during operation must not exceed 90 psi(6.3bar). Higher air pressure may create unsafe operating conditions for the tool and the user.
3. The compressed air should be cooled and have a water filter installed at the outlet end of the compressor. Even with a water filter installed, some water may still condense in the piping or hose and will enter the tool mechanism causing premature damage to the tool. Therefore, it is recommended to install an air filter-lubricator device somewhere between the tool and the compressor.
4. Always use an air compressor of the proper capacity to operate each tool.
5. Clean the hose with a blast of compressed air before connecting the hose to the air tool. This will prevent both moisture and dust inside the hose from entering the tool and causing possible rust or malfunction.

Warning

1. This tool should only be used as a hand operated tool. It is powered by compressed air and is not insulated against electric shock.
2. This tool is specially designed for tightening or loosening bolts or nuts. Any application or use of this tool other than what it is designed for is strictly prohibited.
3. Use only pneumatic impact sockets and accessories on this tool. Never use hand sockets or accessories.
4. High sound levels may cause hearing damage. Always wear hearing protection when operating this tool.
5. Wearing eye/face protection can reduce the danger of high-speed socket being ejected from the tool, due to improper socket insertion during operation.
6. User must wear proper clothing. Loose clothing, long hair, stings, straps, belts and jewelry should not be worn when operating this tool.
7. Before using these tools, make sure that all couplings and plugs are securely mounted. Air hoses which are under pressure will cause a whipping action when disconnecting, this can lead to serious injury!
8. Make certain to stand on a solid or firm location and keep body in well-balanced position while operating this tool.

9. Test run the tool to confirm the rotation direction before practical use. This will reduce the potential hazard due to unexpected rotating direction.
10. In case of tool insert failure, always keep hands away from rotating socket to reduce the risk of being injured, especially when working in confined spaces.
11. Always turn off the air supply and disconnect the air hose before changing socket or making adjustments on the tool.
12. Release the throttle trigger to avoid danger if there is a failure of energy supply and when connecting or disconnecting the air hose.
13. Prolonged use will cause user fatigue. Periodic breaks are recommended for user safety.
14. It is recommended to stop operating the tool whenever the user experiences discomfort, tingling or pain during use.
15. Beware if the compressed air hose breaks unexpectedly, or is being connected or disconnected improperly. This whipping action may cause injury.
16. Always use caution when operating this tool to prevent injury.
17. Avoid storing this tool where it is subject to high humidity.

IDEAL SYSTEM CONNECTION

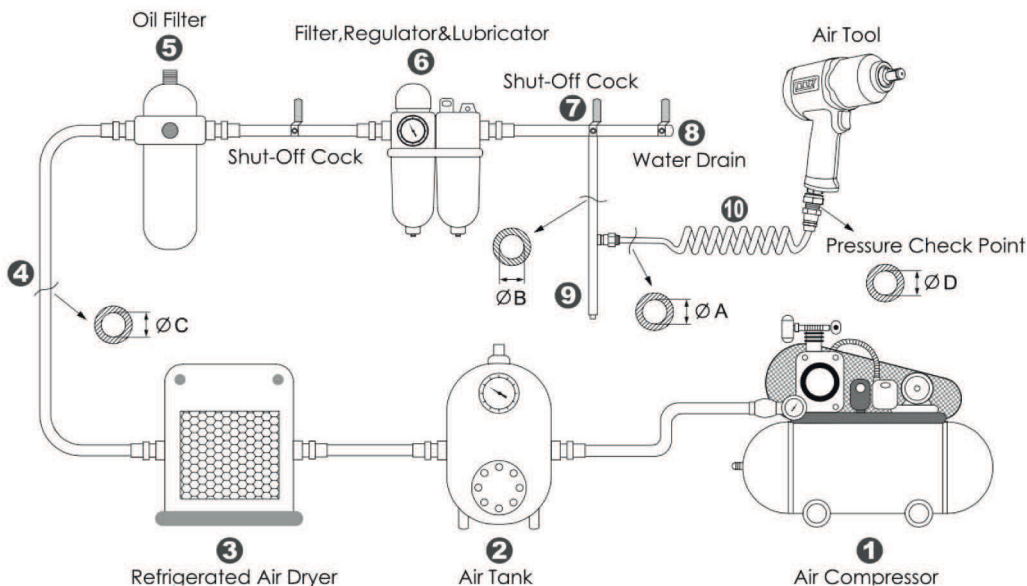

Piping diameters and length requirement

The diameter ØA required for the inlet pipe 10 is recommended on the specification table.

The diameter ØB required for the branch pipe (from 7 to 9) should be 2 times as large as ØA . $\text{ØB} = 2 \times \text{ØA}$

The diameter ØC required for the primary air supply (from 1 to 8) should be 3 times as large as ØA . $\text{ØC} = 3 \times \text{ØA}$

The length for the inlet pipe 10 should be less than 15 feet (4.5m).

MAINTENANCE

1. Before connecting the air hose to this tool or after operating, apply 4 or 5 drops of pneumatic oil into the air inlet and run it for several seconds, referring this operation to the attached illustration
2. Maintain this tool regularly by performing the same oiling application every 3 to 4 hours of operation.
3. Do not lubricate tools with flammable or volatile liquids. Use only the lubricant recommended by authorized dealers. Any other lubricant will lead to reduce performance of the tool and permanent damage. Whenever any unauthorized lubricant is used by accident, flush it immediately with recommended pneumatic oil.
4. Follow all the recycling laws of waste disposal once this tool is no longer usable.

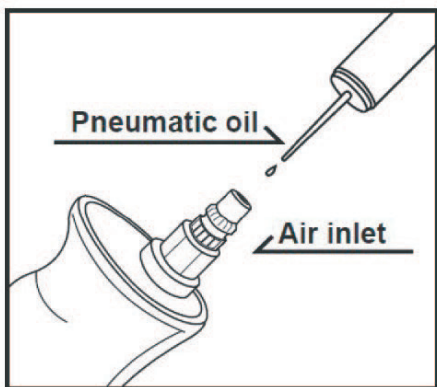

SPECIFICATIONS

RP7460	
Max Reverse Torque	1800Nm
Overall Length	208mm (8.2")
Free Running Speed	7,000rpm
Square Drive	3/4"
Air Inlet Size	10mm (3/8")
Air Hose	10mm (3/8")
Working Pressure	90PSI (6.3Bar)
Air Consumption	230 l/min (9.5cfm)
Net Weight	3 kg (6.6 lbs)
2 speed Forward, 1 speed reverse	

All dimensions are approximate. Images for illustration purposes only.

PARTS OF THE IMPACT WRENCH

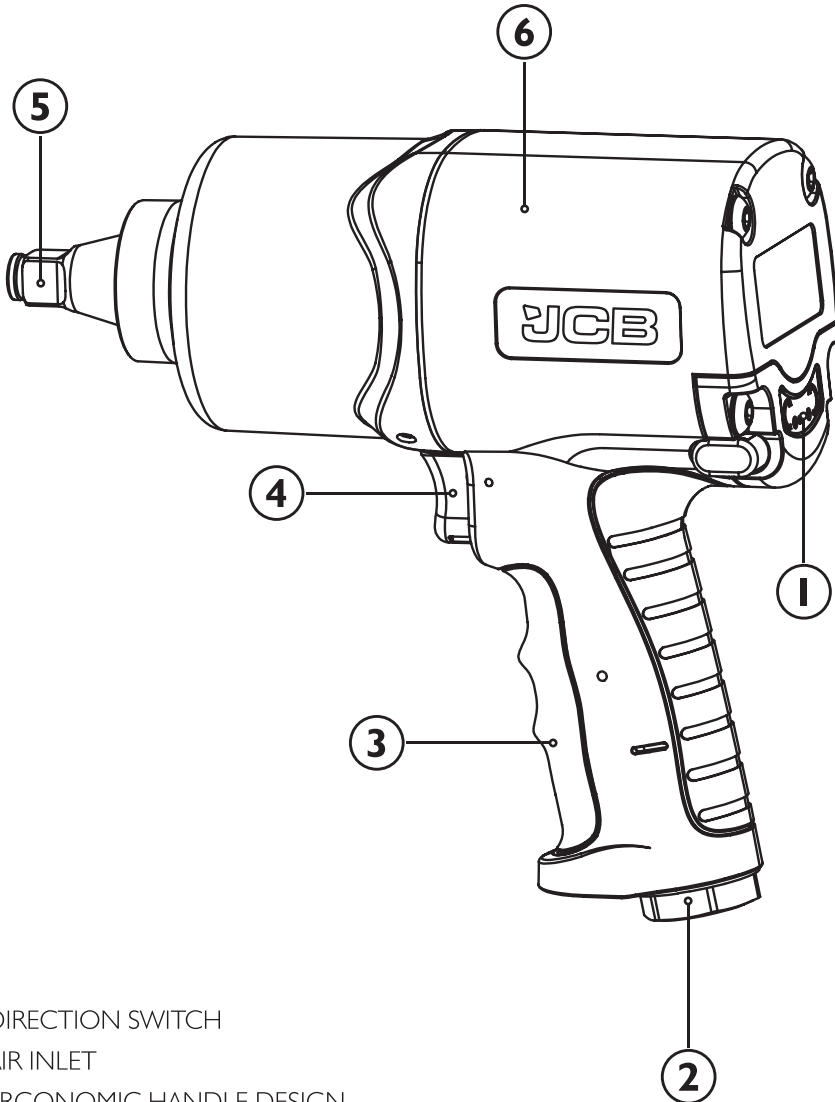

1. DIRECTION SWITCH
2. AIR INLET
3. ERGONOMIC HANDLE DESIGN
4. TRIGGER
5. SQUARE DRIVE HEAD 3/4"
6. TWIN HAMMER MECHANISM

WARRANTY STATEMENT

JCB Power Tools are guaranteed against manufacturing defects for 3 year. Proof of purchase required. This does not affect your statutory rights.

To register your JCB Power Tool, please visit: jcb-tools.com

Warranty cover commences from the date of purchase on the retail sales receipt and is valid only for JCB Tools products bearing the CE and UKCA mark and a visible serial number.

In the unlikely event your JCB Power Tool is subject to a manufacturing fault within the warranty period, JCB Tools may repair the product by replacing defective parts free of charge at our discretion. In the event parts are irreplaceable JCB Tools may replace your product free of charge. The original product will remain the property of JCB Tools in this situation.

The above repair or replacement of products will be undertaken providing that:

- › The product has been subject to fair wear and tear only.
- › The product has not been subject to accidental or cosmetic damage.
- › The product has not been misused and has been used only in accordance with the instruction manual provided.
- › The product has not been subject to overload or insufficient servicing and maintenance.
- › The product has not been subject to any abnormal environmental conditions or inappropriate operating conditions.
- › Repairs have not been attempted by an unauthorised person and no modifications have been made to the product.
- › Repairs have not been undertaken using non-genuine spare parts.

JCB Power Tools used for Hire Fleets or as part of B2B and Service Contracts are not covered by these terms and conditions.



JCB Tools 3 Year Warranty excludes the following (where applicable):

- › Components normally subject to wear such as carbon brushes.
- › Batteries, Chucks and Chargers.
- › Accessories and consumable items.
- › Cases and tool storage products.

If your product develops a fault within 30 days of purchase, return it to the retailer where it was purchased together with your sales receipt. If a product develops a fault after 30 days a warranty claim must be submitted.

JCB TOOLS WILL NOT BE LIABLE FOR ANY INJURIES OR CONSEQUENTIAL DAMAGES RESULTING FROM USE OF THIS PRODUCT.



EU DECLARATION OF CONFORMITY				UK DECLARATION OF CONFORMITY
1.	PRODUCT(S) COVERED BY THIS DECLARATION:	Product: UK Product Code No. EU Product Code No. Factory Reference No.	3/4" Air Impact Wrench RP7460 RP7460 RP7460	Batch/PO No. RP220718-HB-2
2.	IDENTIFICATION DETAILS OF MANUFACTURER:	Name: Address: Country:	Yellow and Black Tools Ltd. (T/A: JCB Tools) Unit 55 Romsey Industrial Estate, Greatbridge Road Romsey, Hampshire SO51 0HR UK	
	AUTHORISED REPRESENTATIVE:	Name: Address: Country:	Trade House Forsage Instrument Pol. Sp. z o. o. 15-561, Grodecka 1A, Biakystok, Polska. Poland	
3. THIS DECLARATION OF CONFORMITY IS ISSUED UNDER THE SOLE RESPONSIBILITY OF THE MANUFACTURER				
4.	OBJECT OF THE DECLARATION:	Product: Function:	3/4" Air Impact Wrench General engine repair, home projects, and light industrial applications	
5i.	THE OBJECT OF THE DECLARATION DESCRIBED IN POINT 4 IS IN CONFORMITY WITH THE RELEVANT UNION HARMONISATION LEGISLATION:	2006/42/EC	The Machinery Directive	
5ii.	THE OBJECT OF THE DECLARATION DESCRIBED IN POINT 4 IS IN CONFORMITY WITH THE RELEVANT UK STATUTORY INSTRUMENTS:	2008 No. 1597	The Supply of Machinery (Safety) Regulations 2008	
6.	REFERENCES TO THE RELEVANT HARMONISED SAFETY STANDARDS USED OR REFERENCES TO THE OTHER TECHNICAL SPECIFICATIONS IN RELATION TO WHICH CONFORMITY IS DECLARED:	EN ISO 11148-6-2012	Hand-held non-electric power tools - Safety requirements - Part 6: Assembly power tools for threaded fasteners	
7.	ADDITIONAL INFORMATION, THE TECHNICAL DOCUMENTATION FOR THE MACHINERY IS AVAILABLE FROM:	Name: Address: Country:	N/A	
SIGNED FOR AND ON BEHALF OF:		YELLOW AND BLACK TOOLS LTD, ROMSEY, UK, 12/06/2023 JAMES BINGHAM OPERATIONS DIRECTOR		
PLACE OF ISSUE:				
DATE OF ISSUE:				
NAME:				
FUNCTION:				
SIGNATURE:				



EU IMPORTER:

Trade House Forsage Instrument
Pol. Sp. z o.o. 15-561, Gródecka 1A,
Białystok, Polska.



DOWNLOAD YOUR INSTRUCTION MANUAL

AE

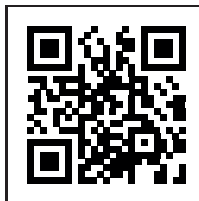

BG

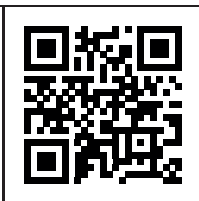

DE

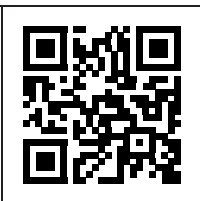

ES

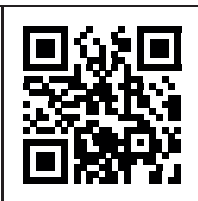

FR

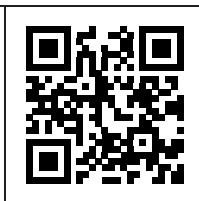

HU

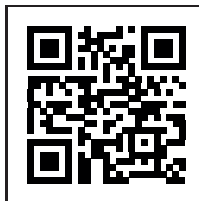

PL

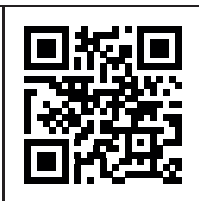

RU

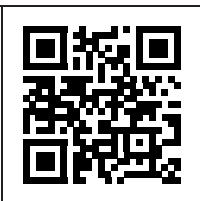

TR

